

SITE E

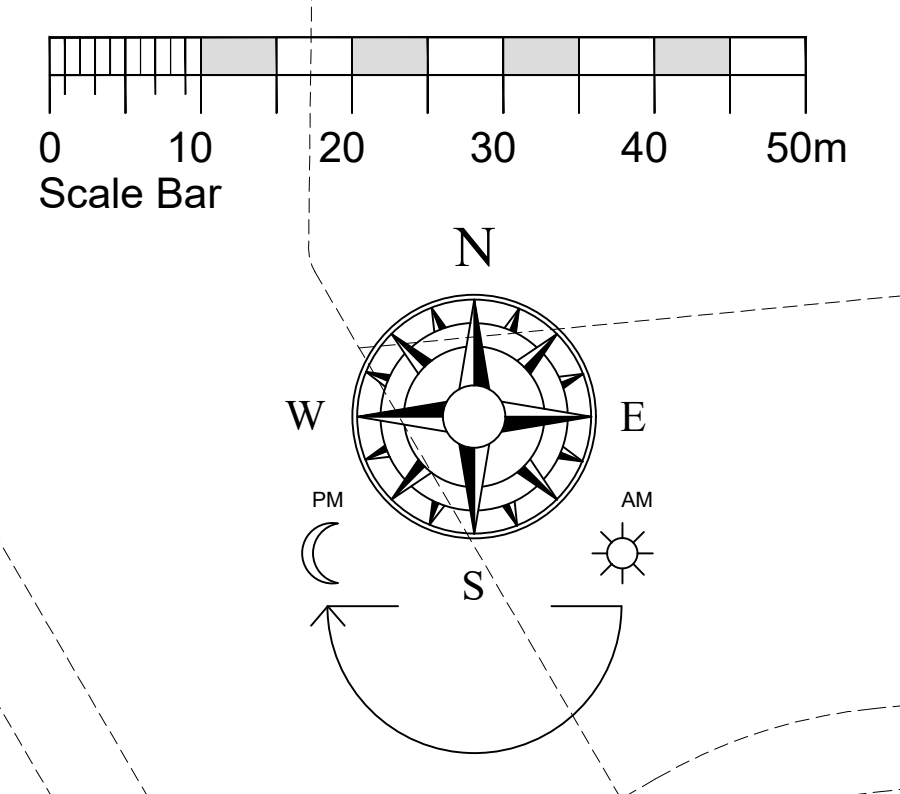

The Development registered under title AYR129269 and plots 1 to 146 within have been DPA approved by:
Craig McFadden - 4 May 2022
 Craig McFadden (DPA Officer)

- - - DEVELOPMENT BOUNDARY
- PLOT BOUNDARY
- PUBLIC OPEN SPACE
- SHARED DRIVEWAY
PLOTS 8 & 9
- SHARED DRIVEWAY
PLOTS 86 & 87
- DRIVEWAY / PEDESTRIAN LINK:
AREA TO BE IN COMMON
DEVELOPMENT OWNERSHIP.
VEHICLE ACCESS FOR PLOTS 124
& 125 ONLY
- SHARED REAR ACCESS PATH
PLOTS 21 & 22
- SHARED REAR ACCESS PATH
PLOTS 30, 31 & 32
- SHARED REAR ACCESS PATH
PLOTS 102 & 103
- SHARED REAR ACCESS PATH
PLOTS 121 & 122
- NON-ADOPTED VISITOR
PARKING SPACES



AMENDMENTS

Issue	Date	Detail
B	03.05.22	Plots 116 / 117 boundary added
A	30.03.22	Plots 1, 2, 8 & 9 boundaries amended

Bellway
 Hamilton Business Park
 Caird Street
 Hamilton ML3 0QA
 Telephone 01698 477440
 Fax 01698 477441
 www.bellway.co.uk

Project
**Montgomerie Park Irvine
 Site A & B**

Drawing
DPA

Scale	Drawn By	Checked
1:500@A0	GK	
Date	Drawing No	
18.03.22	IE/DPA/01	B