



LEGEND

- DENOTES SITE BOUNDARY
- DENOTES INDIVIDUAL PLOT BOUNDARY.
- DENOTES ROADS / FOOTPATHS / PARKING TO BE ADOPTED BY THE LOCAL AUTHORITY.
- DENOTES SERVICE STRIPS / BIO-RETENTION ADOPTED BY THE LOCAL AUTHORITY AND MAINTAINED BY THE APPOINTED FACTOR.
- DENOTES OPEN SPACE / LANDSCAPING / PLAY AREA OWNED BY THE RESIDENTS AND MAINTAINED BY THE APPOINTED FACTOR. (INCLUDES UTILITIES SERVITUDE)
- DENOTES PRIVATE PATH MAINTAINED BY APPOINTED FACTOR OWNED BY DEVELOPMENT
- DENOTES PRIVATE PARKING / FOOTPATH / LIGHTING MAINTAINED BY THE APPOINTED FACTOR OWNED BY PLOTS 1 - 54
- DENOTES PRIVATE PARKING / FOOTPATH / LIGHTING MAINTAINED BY THE APPOINTED FACTOR OWNED BY PLOTS 55 - 93
- DENOTES PRIVATE PARKING / FOOTPATH / LIGHTING MAINTAINED BY THE APPOINTED FACTOR OWNED BY PLOTS 94 - 97
- DENOTES PRIVATE PARKING / FOOTPATH / LIGHTING MAINTAINED BY THE APPOINTED FACTOR OWNED BY PLOTS 147 - 173
- DENOTES BIN / CYCLE / WATERPUMP STORE MAINTAINED BY THE APPOINTED FACTOR OWNED BY PLOTS 15 - 54
- DENOTES BIN / CYCLE / WATERPUMP STORE MAINTAINED BY THE APPOINTED FACTOR OWNED BY PLOTS 55 - 82
- DENOTES BIN / CYCLE / WATERPUMP STORE MAINTAINED BY THE APPOINTED FACTOR OWNED BY PLOTS 153 - 173
- DENOTES PRIVATE SHARED DRIVEWAYS / PRIVATE LIGHTING MAINTAINED BY THE APPOINTED FACTOR OWNED PLOTS NOTED BELOW (INCLUDES UTILITIES SERVITUDE)
- DENOTES AREA OF AFFORDABLE HOUSING

- A OWNED BY PLOTS 98 - 102
- B OWNED BY PLOTS 109 + 110

The Development registered under titles LAN107185, LAN110106, LAN192459, LAN237785 & LAN241096 and plots 1 to 173 within have been DPA approved.

The Keeper - 23 February 2024

Keeper for the Registers of Scotland

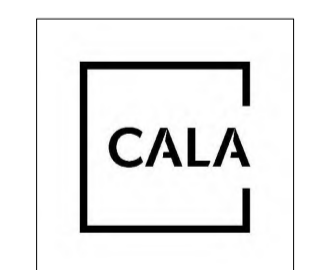

Cairnlee House, Callendar Business Park
Callendar Road, Falkirk, FK1 1XE
tel 01324 600000 fax 01324 600101
www.cala.co.uk

JOB TITLE
**CGA JACKTON
PHASE 1**

DRAWING TITLE
DMS PLAN

SCALE: 1:1000 SHEET SIZE: A1 DATE: 20.05.2021

DRAWN BY: MSM	PRELIMINARY	FINAL	
CHECKED BY:	CENTRAL MASTERED	DEVELOPMENT MASTERED	
SITE	MCCOSKER	VER	MOD
		DRG No.	REV
		DMS/01	I

Copyright Cala Management Limited

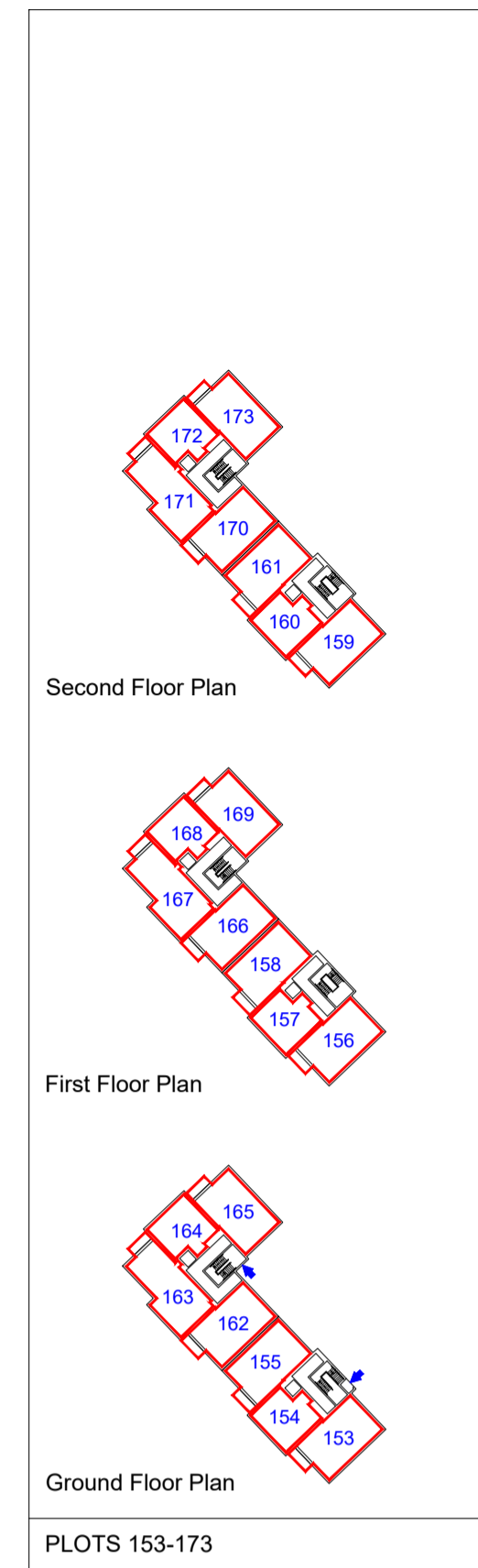
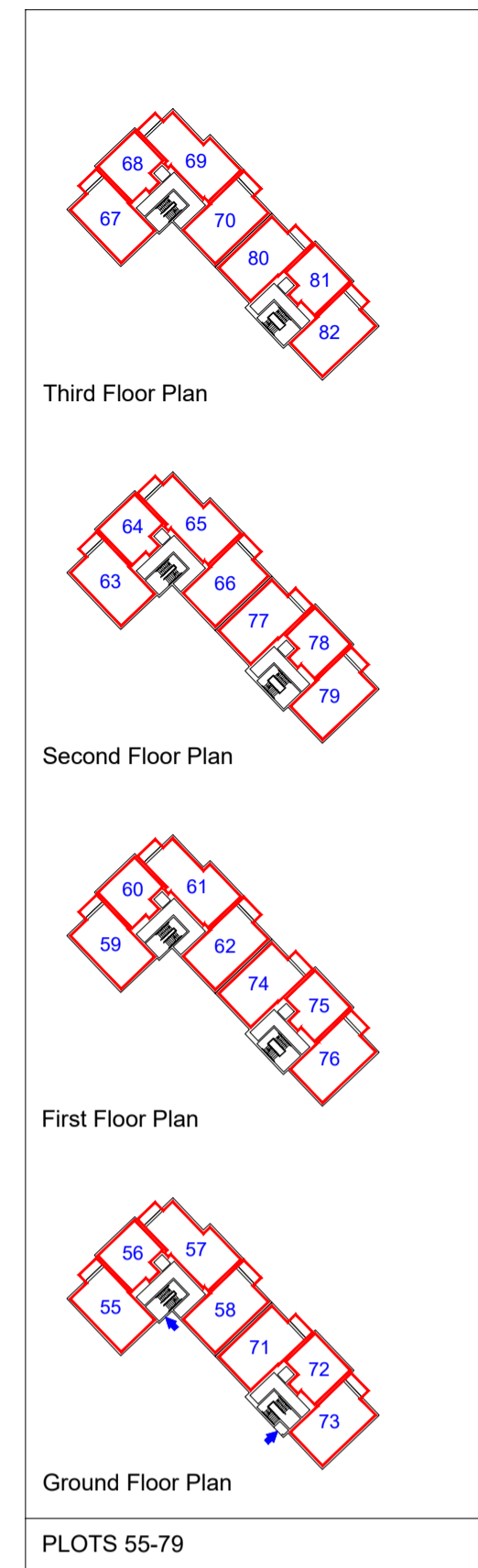
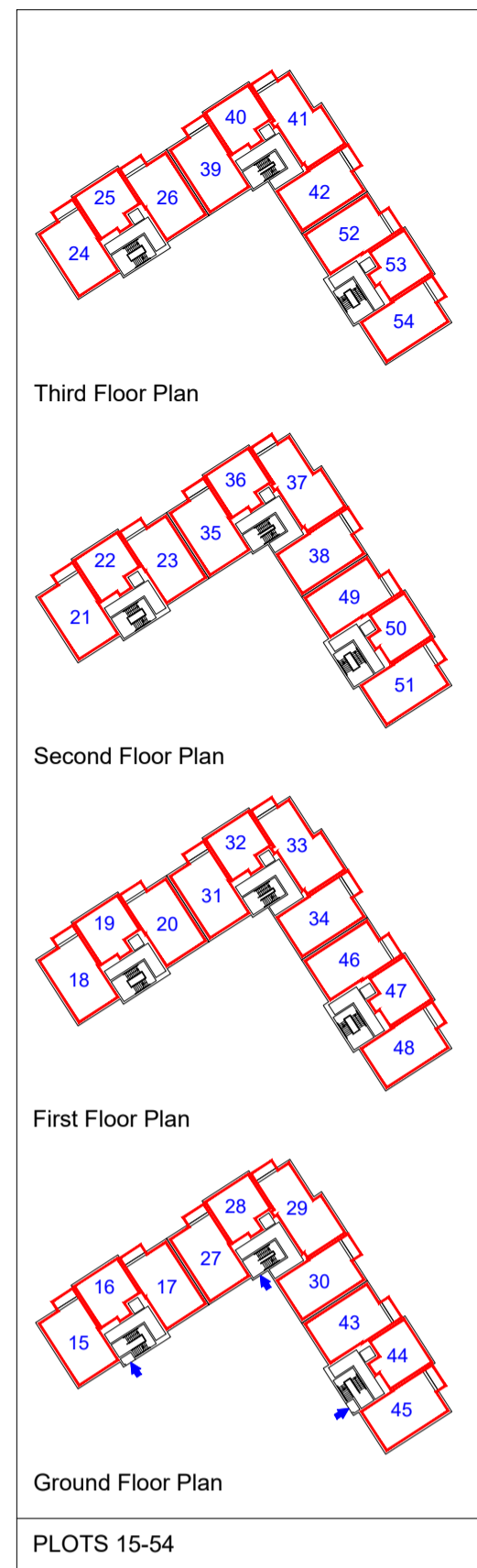

LEGEND

-  DENOTES SITE BOUNDARY
 -  DENOTES INDIVIDUAL PLOT BOUNDARY.
 -  DENOTES ROADS / FOOTPATHS / PARKING TO BE ADOPTED BY THE LOCAL AUTHORITY.
 -  DENOTES SERVICE STRIPS / BIO-RETENTION ADOPTED BY THE LOCAL AUTHORITY AND MAINTAINED BY THE APPOINTED FACTOR.
 -  DENOTES OPEN SPACE / LANDSCAPING / PLAY AREA OWNED BY THE RESIDENTS AND MAINTAINED BY THE APPOINTED FACTOR. (INCLUDES UTILITIES SERVITUDE)
 -  DENOTES PRIVATE PATH MAINTAINED BY APPOINTED FACTOR OWNED BY DEVELOPMENT
 -  DENOTES PRIVATE PARKING / FOOTPATH / LIGHTING MAINTAINED BY THE APPOINTED FACTOR OWNED BY PLOTS 1 - 54
 -  DENOTES PRIVATE PARKING / FOOTPATH / LIGHTING MAINTAINED BY THE APPOINTED FACTOR OWNED BY PLOTS 55 - 93
 -  DENOTES PRIVATE PARKING / FOOTPATH / LIGHTING MAINTAINED BY THE APPOINTED FACTOR OWNED BY PLOTS 94 - 97
 -  DENOTES PRIVATE PARKING / FOOTPATH / LIGHTING MAINTAINED BY THE APPOINTED FACTOR OWNED BY PLOTS 147 - 173
 -  DENOTES BIN / CYCLE / WATERPUMP STORE MAINTAINED BY THE APPOINTED FACTOR OWNED BY PLOTS 15 - 54
 -  DENOTES BIN / CYCLE / WATERPUMP STORE MAINTAINED BY THE APPOINTED FACTOR OWNED BY PLOTS 55 - 82
 -  DENOTES BIN / CYCLE / WATERPUMP STORE MAINTAINED BY THE APPOINTED FACTOR OWNED BY PLOTS 153 - 173
 -  DENOTES PRIVATE SHARED DRIVEWAYS / PRIVATE LIGHTING MAINTAINED BY THE APPOINTED FACTOR OWNED PLOTS NOTED BELOW (INCLUDES UTILITIES SERVITUDE)
 -  DENOTES AREA OF AFFORDABLE HOUSING
- (A) OWNED BY PLOTS 98 - 102
- (B) OWNED BY PLOTS 109 + 110

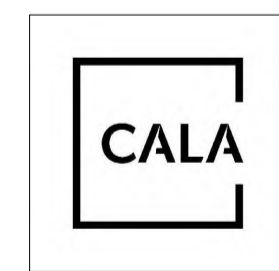

Cairlee House, Callendar Business Park
Callendar Road, Falkirk, FK1 1XE
tel 01324 600000 fax 01324 600101
www.cala.co.uk

JOB TITLE
**CGA JACKTON
PHASE 1**

DRAWING TITLE
DPA PLAN

SCALE: 1:1000 SHEET SIZE: A1 DATE: 25.08.2021

DRAWN BY: MSM	PRELIMINARY	FINAL
CHECKED BY: CENTRAL MASTERED	DEVELOPMENT MASTERED	
SITE: 267	MCCOSKER	VER MOD DRG No. REV PLOT
		DPA/01 G

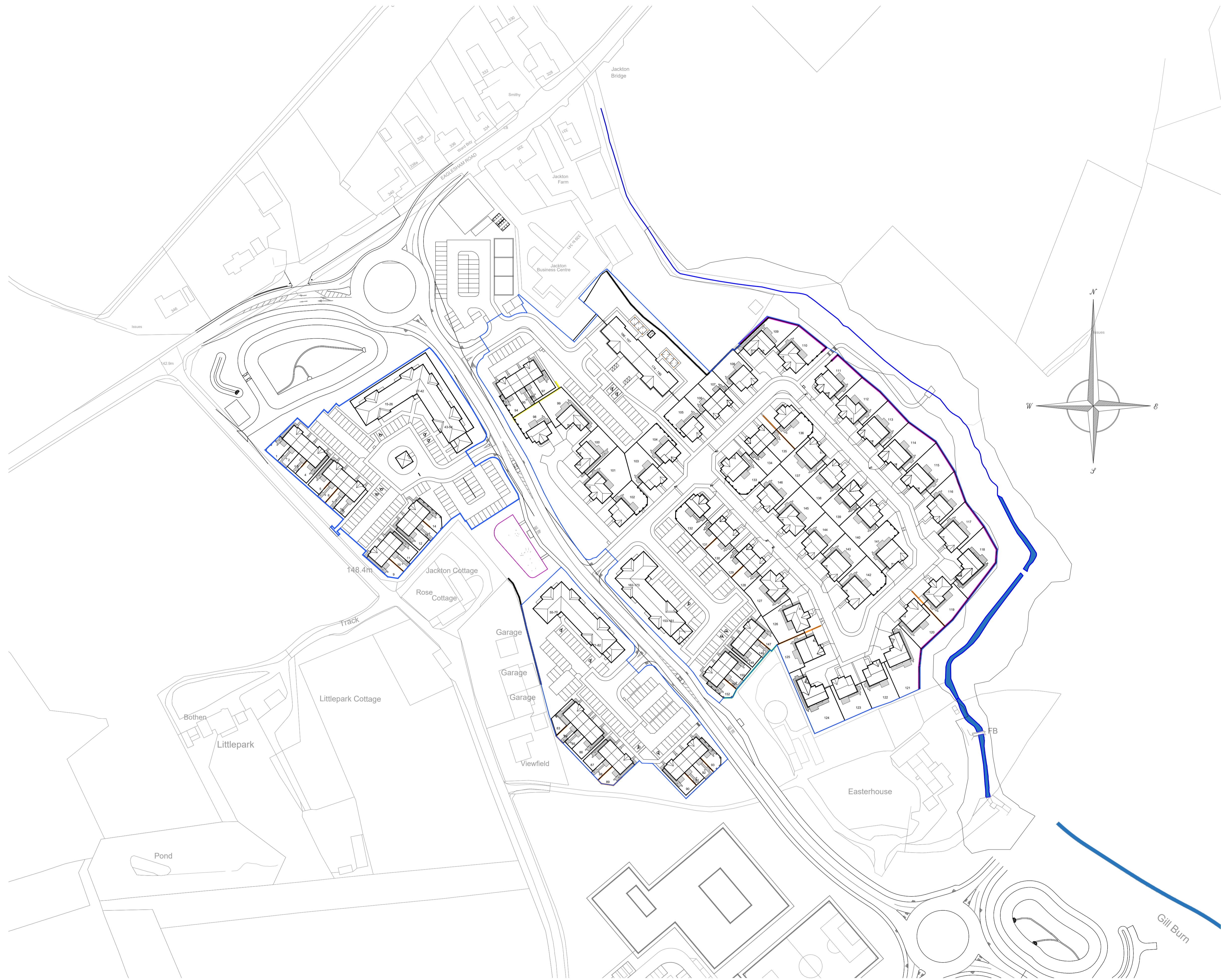

LEGEND

- DENOTES SITE BOUNDARY
- DENOTES RETAINING WALLS OWNED AND MAINTAINED BY ASSOCIATED PLOTS ON EACH SIDE.
- DENOTES RETAINING WALLS SOLELY OWNED BY PLOTS 94-99 AND MAINTAINED BY THE APPOINTED FACTOR.
- DENOTES RETAINING WALLS SOLELY OWNED BY PLOTS 147-152 AND MAINTAINED BY THE APPOINTED FACTOR.
- DENOTES GABION WALLS MAINTAINED BY THE APPOINTED FACTOR.

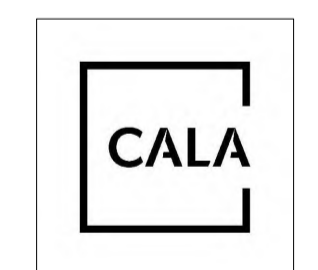
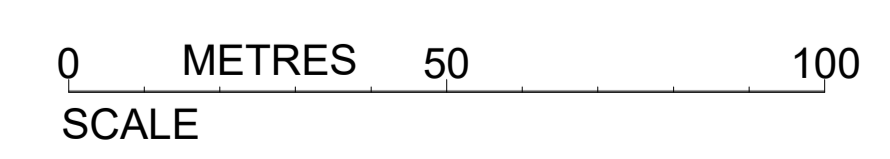
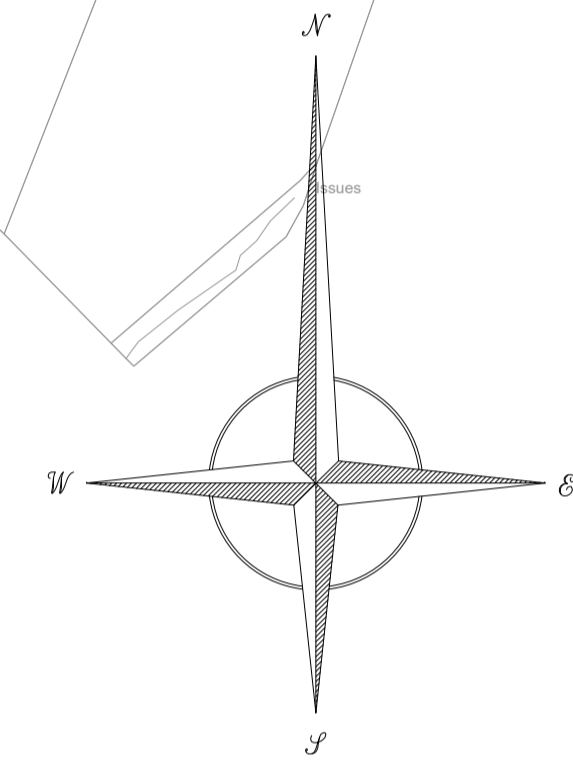

Cairlee House, Callendar Business Park
 Callendar Road, Falkirk, FK1 1XE
 tel 01324 600000 fax 01324 600101
 www.cala.co.uk

JOB TITLE
**CGA JACKTON
 PHASE 1**

DRAWING TITLE
RETAINING WALL DEED PLAN

SCALE: 1:1000 SHEET SIZE: A1 DATE: 20.05.2021

DRAWN BY: MSM	PRELIMINARY	FINAL	
CHECKED BY:	CENTRAL MASTERED	DEVELOPMENT MASTERED	
SITE	MCCOSKER	VER	MOD
		DRG No.	REV
		DMS/02	PLOT
			G